

Modeling the Thermal Behavior of Biosphere 2 in a Non-Controlled Environment Using Bond Graphs

Angela Nebot
Llenguatges i Sistemes Informàtics
Universitat Politècnica de Catalunya
Diagonal 647, 8na. planta
Barcelona 02028
Espanya
Nebot@IC.UPC.ES

François E. Cellier
Dept. of Electr. & Comp. Engr.
The University of Arizona
P.O.Box 210104
Tucson, Arizona 85721-0104
U.S.A.
Cellier@ECE.Arizona.Edu
<http://www.ece.arizona.edu/~cellier>

Francisco Mugica
Depto. de Energía Nuclear
Instituto de Investigaciones Eléctricas
Reforma No.113 Col. Palmira
62001 Cuernavaca, Morelos
México
Mugica@IIE.Org.MX

Abstract

Biosphere 2 is a closed ecological system of high complexity built to deepen the understanding of ecological systems, to study the dynamics of closed ecologies, and to learn to control their behavior. The use of modeling and simulation is crucial in the achievement of these goals. Understanding a physical system is almost synonymous with possessing a model of its compartment.

The main goal of this study is the development of a dynamic bond graph model that represents the thermal behavior of the complex ecological system under study, Biosphere 2. In this work, a first model that captures the behavior of the ecological system in a non-controlled environment is presented.

Keywords: Ecological systems; Object-oriented modeling; Bond graphs; Quantitative simulation.

Introduction

A non-controlled thermal behavior model of Biosphere 2 has been developed by means of bond graphs, a tool for the graphical representation of energy flows through (power balance in) a system, a safe and appealing way of dealing with complex systems [1]. The model is based on a previous research effort by F. Luttmann [3].

The bond graph model has been coded in the Dymola language [2], an object-oriented modeling environment designed for complex physical system modeling. Dymola fully supports the reuse of models by means of libraries containing model classes from

which individual models (objects) can be instantiated, and by means of class inheritance. Dymola can be used as a code generator for many different simulation software tools, such as ACSL, Desire, Simnon, and Simulink, as well as DSblock (Fortran) and Dymosim (C).

1 Biosphere 2

Biosphere 2 is a closed ecology project located some 35 miles north of Tucson. With its 1800 sensors being recorded once every 15 minutes (on the average), Biosphere 2 is the largest closed ecology system ever built by mankind. Figure 1 shows Angela Nebot and Jack Corliss in front of one of many multi-sensor instruments located in the lower savannah area of Biosphere 2.

The aim of Biosphere 2 is to study and understand the dynamic relationships between living organisms and their environment. In this light, Biosphere 2 comprises a large-scale modeling effort.

In order to maintain the physical conditions necessary for life to be sustained (temperature, pressure, humidity, CO₂ contents in the air, to mention just the most important ones), Biosphere 2 contains a very complex air circulation system. In this light, Biosphere 2 is one of the most complex technological systems ever built by mankind.

Accordingly, Biosphere 2 represents extraordinary challenges to both science and engineering. With its new management (Biosphere 2 has recently become a National Laboratory managed by Columbia University) came a somewhat modified charter. Had Biosphere 2 been viewed previously as an experimental



Figure 1: Multi-Sensor Instrument in Lower Savannah

setup for the study of closed ecologies, it is now seen more as an instrument to further the understanding of the relationships between living organisms and their environment, an instrument that shall ultimately help us navigate our spaceship Earth from an operational mode of constant expansion and exploitation into one of equilibrium and sustainability.

With this modified charter came a different way of using the instrument. Had Biosphere 2 before been used as one experimental setup, it has now become a laboratory, in which multiple experiments can be performed simultaneously and in parallel. This creates new challenges for engineering. Before, it had sufficed to keep the physical parameters of Biosphere 2 within acceptable ranges in a steady-state mode of operation. Now that experimentation has assumed a more active role, it is important to understand and be able to predict beforehand what effects engineering decisions will have on the physical parameters of Biosphere 2 both in terms of a modified steady-state operating point as well as during the transitional period. By subdividing Biosphere 2 into smaller units for parallel experimentation, the independent control of each of these entities has become much more difficult.

In this paper, an energy balance model of Biosphere 2 is described. This model does not contain yet the air handlers, i.e., it describes the uncontrolled system. However, this in itself is already a significant step towards an engineering model of Biosphere 2. The air handler model shall be added to the Biosphere 2 model shortly. Due to the object-oriented nature of the bond graph representation, it is fairly easy to augment the model by additional components as needed.

In the current model, Biosphere 2 is represented

as several separate entities linked together by thermal interactions. These entities are the following: *cover*, *internal atmosphere*, *vegetation canopy*, *soil surface*, *pond*, and three *ground layers* below the soil surface. A simplified diagram of the overall structure of the Biosphere 2 model is presented in Fig. 2.

Three separate physical phenomena provide mechanisms for heat flow inside Biosphere 2, namely, *radiation*, *convection*, and *conduction*. In addition, the model contains a description of *evaporation* and *condensation*, i.e., mechanisms for describing the effects of storing and retrieving *latent heat* (humidity).

Figure 2 shows the thermal interactions that are taking place between the different elements inside Biosphere 2.

The conditions that exist outside the biome structure are characterized by three time-dependent processes: the *sky radiant temperature*, the *ambient temperature*, and the *solar energy input*. These three time-dependent functions are provided in a weather file available for the location of Tucson. For Biosphere 2, the data ought to be slightly corrected because of the higher altitude, but this has not yet been done.

The *cover* is a glass dome that hermetically encloses Biosphere 2 from the outside. Figure 3 shows part of the dome covering Biosphere 2. The round structure in the background is one of two lungs responsible for regulating the air pressure inside Biosphere 2.



Figure 3: Biosphere 2 Dome and Lung

Heat is transferred between the cover and the internal entities by radiation and convection. Both *sensible* and *latent* heat convection play important roles inside the biome. For this reason, it was decided to represent, in the bond-graph model, the internal atmo-

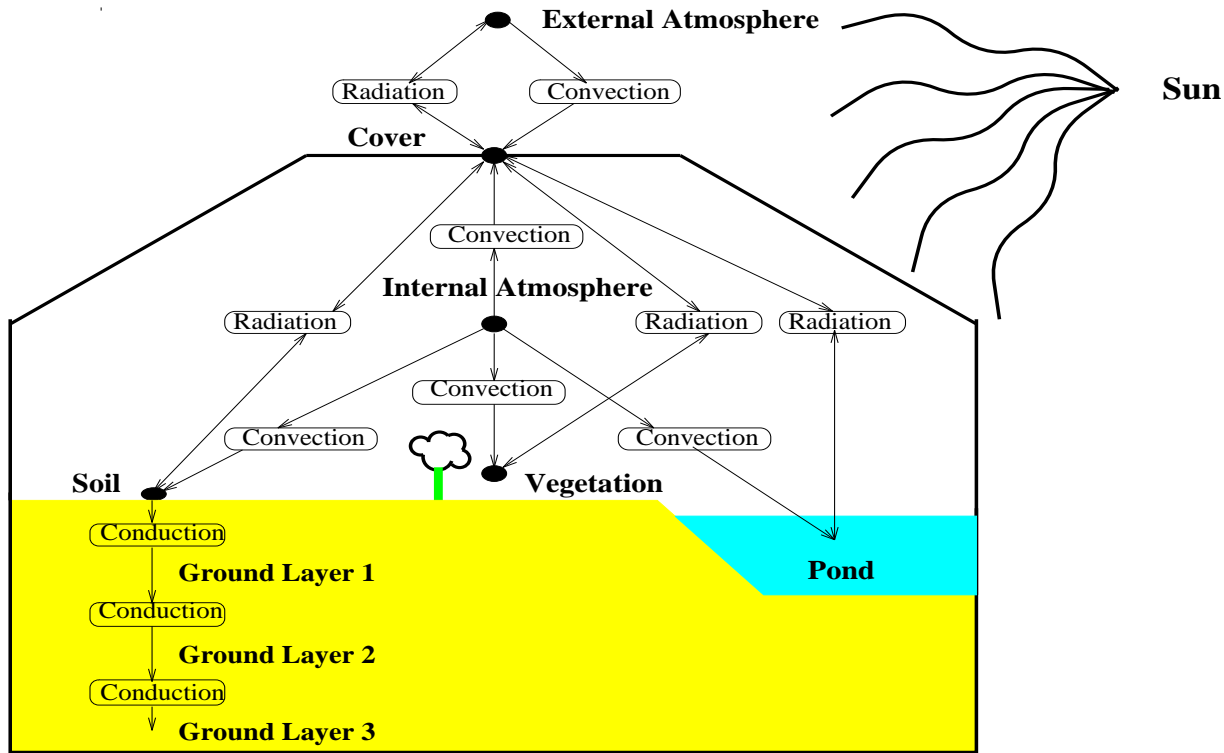

Figure 2: Thermal Interactions Between Entities Inside Biosphere 2

sphere through two separate elements, one that corresponds to the temperature (sensible heat convection), and another that corresponds to the moisture (latent heat convection), as is shown on Fig. 5.

The *internal atmosphere* (air) inside the biome structure is in direct contact with all the other entities except the three ground layers below the soil surface. Both sensible and latent heat convection need to be taken into account. Both types of heat convection take place between the atmosphere and the soil surface, the vegetation canopy, the pond, and the cover.

The thermal processes that affect the *vegetation canopy* are convection and radiation. The vegetation canopy absorbs a part of the solar radiation. The amount of solar radiation absorbed is a function of the total leaf area and the thickness of the canopy.

The canopy emits thermal radiation to the cover, and sensible convection is produced due to the air movement over the leaves. Latent heat convection (evapotranspiration) is produced from the interior of the leaves to the surrounding air. This diffusion process depends not only on the air resistance, but also on the stomatal resistance. The stomatal resistance of the leaf is the opening degree of the leaf pores, and it depends on the light and the water availability.

The *soil surface* is considered an interface between the ground and the air. Heat (sensible heat) and moisture (latent heat) are convected from the soil surface area to the surrounding air. The former is a function of the air motion over the surface, whereas the latter depends on the resistance to vapor diffusion. Heat is transferred by conduction from this layer down to the ground layer below, and it is assumed that no evapotranspiration takes place in the ground layers.

In the *pond*, the same thermal phenomena take place as in the vegetation and soil. A part of the solar radiation that reaches the pond is reflected, whereas the rest is absorbed by the pond. Thermal radiation is transferred between the pond and the cover, and evaporation takes place from the water surface to the surrounding air. Figure 4 shows the pond inside Biosphere 2.

The *ground layer* is divided into three layers to simulate the thermal conduction between them. The thickness of the ground layers can be specified through thermal parameters. It is assumed that no heat loss occurs at the boundaries between the soil of the biome and the ground surrounding it.

Each of the entities is considered to have thermal capacitance. Thermal capacitances are thus associ-

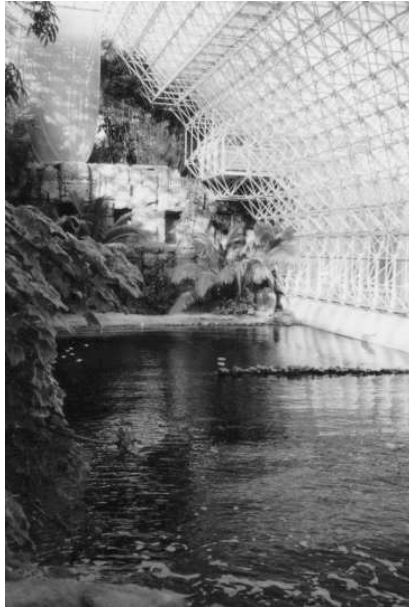

Figure 4: The Pond

ated with the cover, the pond, the three ground layers below the soil surface, the soil surface itself, the vegetation canopy, and the internal atmosphere. An additional capacitive storage element is associated with the atmosphere to reflect its capability of storing moisture.

The thermal state of Biosphere 2 is determined at any time through a set of up to 140 algebraic and differential equations. They represent the energy balance for each of the entities inside Biosphere 2, including the moisture in the internal atmosphere entity. State variables are the temperature values at each node, and the air humidity ratio in the internal atmosphere.

2 Bond Graph Model

The bond graph model of the overall structure is shown in Fig. 5. Notice that the structure of the global bond graph model has a direct mapping to the physical structure of the system.

Each entity is represented by a 0-junction. Capacitances are attached to each of these junctions representing the heat or moisture storage capability of the entity. Flow sources are attached to the cover, the soil, the vegetation, and the pond, modeling the solar input. Effort sources are used to model the ambient temperature and the effective sky radiant temperature.

The radiation, convection, and conduction phenom-

ena that take place between the internal elements of the overall structure are represented as energy flows between the corresponding nodes. The bond graph models representing these flows are instantiations of generic radiation, convection, and conduction models containing, where needed, additional specific equations to compute the parameter values of the generic models.

Three different types of generic models for each of the thermal phenomena appear in the model of Fig. 5: **RA**, **CV**, and **CD**. **RA** is the bond graph generic model for thermal radiation, shown in Fig. 6. **CV** is the bond graph generic model for sensible heat convection, shown in Fig. 7. Finally, **CD** is the bond graph generic model for thermal conduction, shown in Fig. 8.

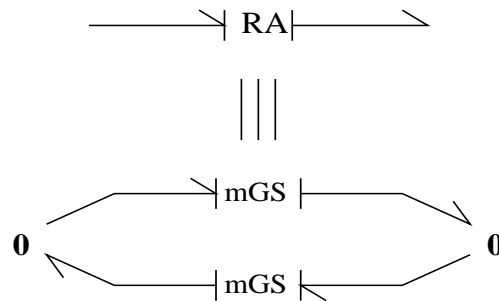

Figure 6: Bond Graph for Thermal Radiation

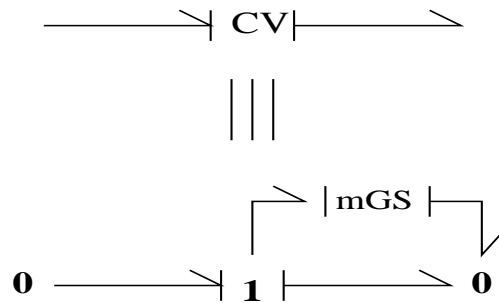

Figure 7: Bond Graph for Sensible Heat Convection

Finally, the conversion between sensible and latent heat is symbolized by the **CW** element, a generic element representing the effects of evaporation and condensation of water. Water vapor, at a given temperature, contains more energy than liquid water. Consequently, when water evaporates, it extracts thermal energy from the environment, thereby cooling down the surrounding environment. On the other hand, when water condensates on a cold surface, it simultaneously heats that surface up. This effect is rarely

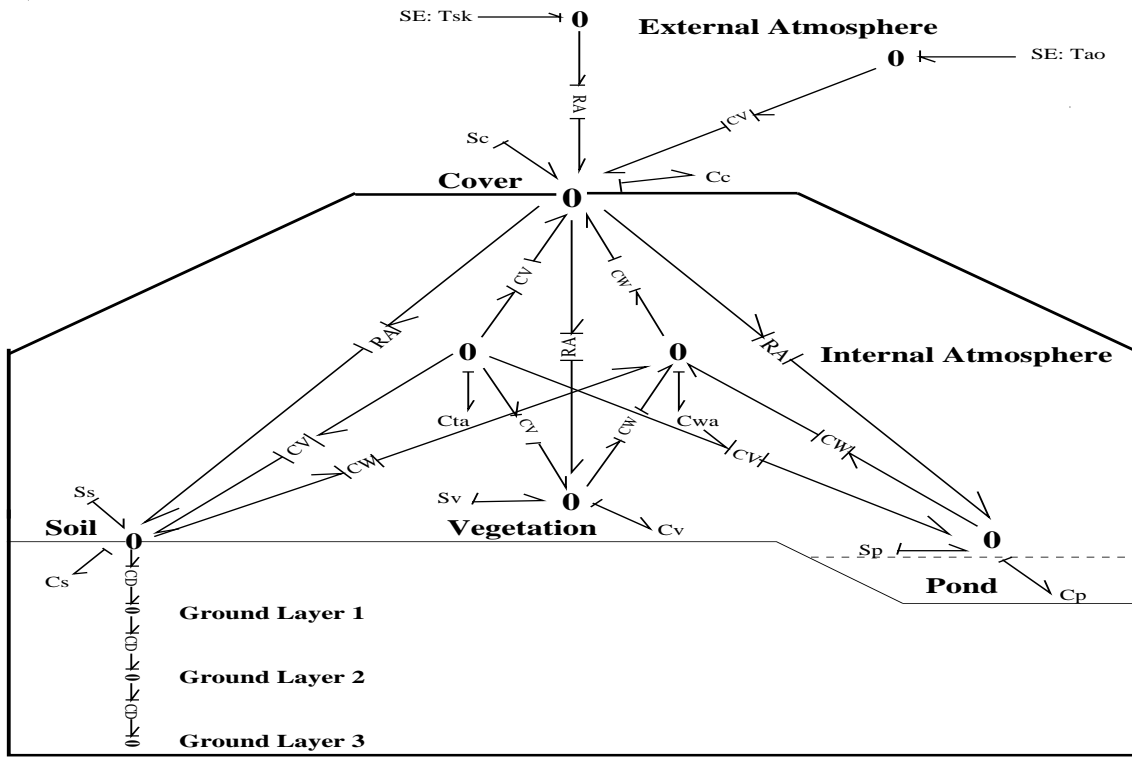

Figure 5: Bond Graph Model for Biosphere 2

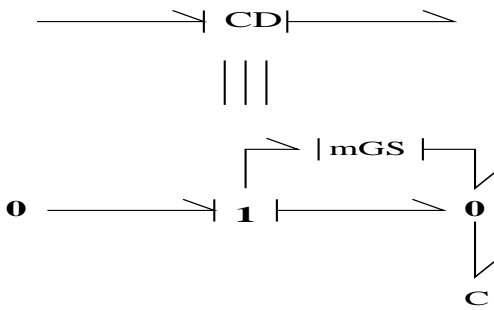

Figure 8: Bond Graph for Thermal Conduction

modeled in an open system, but it cannot be neglected in a closed environment such as Biosphere 2.

3 The Dymola Model

Once the bond graph model of the overall system is described, it is coded in the Dymola modeling language. The software allows to create a library with all the thermal elements representing the different phenomena, and to generate a Biosphere 2 model through instantiation of the thermal interactions that occur

inside Biosphere 2. Dymola then generates automatically a simulation program in a variety of different formats, including ACSL and Dymosim.

3.1 Solar Input

The following model describes the solar input:

```

model class SolarInput
  inherit PhysPar
  main cut A(e/-f)
  parameter m = 11.247, a = 0.
  local so, p
    so = m * rad(Time) + a
    p = e * f
end

```

SolarInput is essentially a generic flow source. *PhysPar* is a model class containing the physical parameters of Biosphere 2. It is inherited, so that it won't be necessary to repeat the values of the global parameters in each model class. *so* is the solar input per square meter. *rad(Time)* is a tabular function with weather data describing the solar input at any point in time for the location of Tucson. *m* and *a* are correction factors. *p* is the thermal power entering the system due to direct solar radiation.

The model is incomplete, because it doesn't compute the actual power available due to radiation. This is then accomplished by specializing the generic model for the purpose of computing the solar input to the cover, the vegetation, the soil, and the pond, separately. The specific pond model takes the following form:

```

model class SUNp
  inherit SolarInput
   $p = ag * so * tau * apix * (1. - refl)$ 
end

```

where ag is the effective surface of Biosphere 2. ag should be a function of time, because it depends on the position of the sun in the sky, but in this simplified model, it was assumed to be constant. tau is the percentage of solar radiation that traverses the cover. Again, this should be a function of time, but currently isn't. $apix$ is the percentage of the total Biosphere 2 surface covered by the pond, and $refl$ is the reflection rate of the pond.

An interesting model is that of the cover.

```

model class SUNc
  inherit SolarInput
  terminal pv, ps, pp
   $p = ag * so * alph + (ag * so * tau - pv - ps - pp) * alph$ 
end

```

The first term denotes the radiation that gets absorbed by the cover. $alph$ is the absorption rate. Clearly, $(1 - alph - tau)$ is the amount of solar radiation that gets reflected back into space. $ag * so * tau$ is the radiation that first penetrated the dome. $pv + ps + pp$ is the amount of radiation that got absorbed by the vegetation, the soil, and the pond. The remaining radiation is inside the dome, and again, a certain percentage thereof ($alph$) gets absorbed by the dome on the way out, whereas the rest escapes back into space.

3.2 Radiation

All the models that describe either radiation, convection, conduction, evaporation, or condensation are two-port elements. Hence it makes sense to design a generic *TwoPort* model class:

```

model class TwoPort
  inherit PhysPar
  cut A( $e1/f1$ ), B( $e2/f2$ )
  main cut C[A,B]
  main path P < A - B >
end

```

The generic *TwoPort* model describes the two interfaces. It also inherits the physical parameters, so that they are available whenever needed.

The generic radiation model takes the following form:

```

model class mGSr
  inherit TwoPort
  local G, G0
   $G * e1 = f1$ 
   $e1 * f1 = e2 * f2$ 
   $G = G0 * sigma * (e1 ** 2)$ 
end

```

The first equation describes Ohm's law. The second equation ensures that no energy is lost, and the third equation describes the value of the conductance G . According to [1], G is proportional to the square of the absolute temperature.

The $G0$ parameter is specific for each of the areas. For example, the specific model for the radiation between cover and pond would be:

```

model class mGScp
  inherit mGSr
   $G0 = ag * apix$ 
end

```

The above model describes either the radiation from the cover to the pond, or vice-versa. The two need to be combined into one model, as shown on Fig. 6:

```

model class RAcp
  submodel (mGScp) mGScp1, mGScp2
  connect mGScp1 from A to B
  connect mGScp2 from B to A
end

```

This model is now ready for use in the main model describing the Biosphere 2 structure.

3.3 Convection

The generic convection model takes the following form:

```

model class mGSc
  inherit TwoPort
  local G, G0
   $G * e1 = f1$ 
   $e1 * f1 = e2 * f2$ 
   $G = G0 / (e1 + e2)$ 
end

```

It is very similar to the generic radiation model. However, according to [1], the conductance is here inverse proportional to the input temperature. Looking at Fig. 7, it is evident that $e1$ represents the difference between input temperature and output temperature, whereas $e2$ is the output temperature. Hence $G0$ must be divided by the sum of $e1$ and $e2$.

Looking again at the pond, the following specific model is derived:

```

model class mGSqp
inherit mGSc
  G0 = ag * apix * (b1 + b2 * v)
end

```

where the $b1$ term describes the conduction across the surface of the pond, and $b2*v$ describes the convection in the boundary layer above the pond.

According to Fig. 7, this model can be embedded in the corresponding *TwoPort* model:

```

model class CVqp
submodel (mGSqp) mGSqp1
submodel (bond) B1, B2, B3
node n1, n2
  connect B1 from A to n1
  connect B2 from n1 to B
  connect B3 from n1 to n2
  connect mGSqp1 from n2 to B
end

```

Also this model is now ready for use in the main model.

3.4 Evaporation and Condensation

The generic evaporation model takes the following form:

```

model class mGSw1
inherit TwoPort
local G, p, svp, hum
  svp = 0.61078 * exp(17.269 * (e1 - 273.15) / (e1 - 35.85))
  hum = 0.62198 / ((pao / svp) - 1.)
  p = G * (hum - e2)
  p = e1 * f1
  p = e2 * f2
end

```

In this model, the input side represents sensible heat. $e1$ is the temperature, and $f1$ represents entropy flow into the transformation. The output side represents latent heat. $e2$ is the humidity ratio, and $f2$ is the latent heat flow per humidity. svp is the saturation vapor pressure, calculated according to Tetens's law. hum is the corresponding humidity ratio. The power p is proportional to the difference between the calculated humidity ratio of the evaporating surface and the true humidity ratio of the air. The calculations of the specific conductances G for the pond, the vegetation, and the soil are a little more complicated, and shall not be given here.

The condensation model is basically the same as the evaporation model, except that here the input side represents latent heat, whereas the output side represents sensible heat:

```

model class mGSw2
inherit TwoPort
local G, p, svp, hum

```

```

  svp = 0.61078 * exp(17.269 * (e2 - 273.15) / (e2 - 35.85))
  hum = 0.62198 / ((pao / svp) - 1.)
  p = G * (e1 - hum)
  p = e1 * f1
  p = e2 * f2
end

```

This completes the description of the individual library modules.

3.5 The Overall Model

The overall model is trivial, but too long to be listed here. It simply invokes the individual library modules as submodels, and then connects them in accordance with Fig. 5. Each 0-junction is represented as a node in the main model.

4 Simulation Results

The model was simulated over the first three days of June, using the data provided in the weather data files, and assuming a uniform initial temperature of 295.0 K and an initial relative air moisture of 1% everywhere within Biosphere 2. The results for the air temperature and moisture are given in Fig. 9.

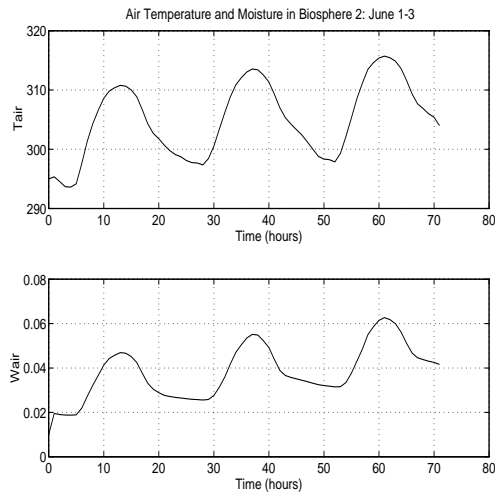

Figure 9: Simulation Results

The slight upward trend in both graphs indicates that the chosen initial conditions do not represent correct steady-state values for the location of Biosphere 2 and the chosen date of the year.

5 Summary and Conclusions

In this work, a model capturing the thermic behavior of Biosphere 2 in a non-controlled environment, i.e., without the active temperature control units, has been presented. In a future research effort, this model will be enhanced by adding the effects of the control elements such as: air handlers, fans, and heat exchanger coils. The controlled environment model will be an excellent tool for studying the system under different operational conditions. Such a tool is not currently available to the scientists designing experiments to be performed in Biosphere 2. Consequently, each new experiment presents a risk to the integrity of the system. The new model, once fully developed, shall reduce these risks and allow the conceptualization and optimization of scientific experiments prior to their actual implementation in Biosphere 2.

The bond graph modeling paradigm turned out to be an excellent choice for describing the different thermic properties of Biosphere 2 in a totally modular, object-oriented framework.

Acknowledgments

Angela Nebot acknowledges gratefully the financial support received for the research described in this article by the *Direcció General de Recerca* of the *Generalitat de Catalunya* in the form of a *beca postdoctoral per a joves investigadors (BE)*, grant number 1995BEAI300068.

References

- [1] F. E. Cellier, *Continuous System Modeling*, Springer-Verlag, New York, 1991.
- [2] H. Elmqvist, *Dymola — Dynamic Modeling Language, User's Manual*, Dynasim AB, Lund, Sweden, 1995.
- [3] F. Luttmann Valencia, *A Dynamic Thermal Model of a Selfsustaining Closed Environment Life Support System*, Ph.D. Dissertation, University of Arizona, Tucson, 1990.